

BEHÄLTER

aus 18/10 Stahl, Aluminium und Nickel

CONTAINER

out of stainless steel, aluminium and nickel

CONTAINER

en acier inoxydable, aluminium et nickel

CONTENEDORES

De acero inoxidable, aluminio y níquel



■ BEHÄLTER

Die Produktgruppe Behälter aus Edelstahl enthält alle im Labor benötigten Gefäße, Schaufeln, Schöpfkellen, Trichter und Reagenzglasgestelle. Sowie Tiegel und Schalen aus Reinnickel (99,5%).

■ CONTAINER

The product group container made of stainless steel contains all types of vessels which are needed in the laboratory, scoops, ladles, funnels and testtube-stands as well as crucibles and dishes made of pure nickel (99,5%).

■ CONTAINER

Ce groupe de produits comprend tous les récipients nécessaires dans un laboratoire, pelles, louches, entonnoirs et support de tubes d'essai. Ainsi que creusets et capsules en nickel pur (99,5%).

■ CONTENEDORES

El grupo de productos contenedores, hechos de acero inoxidable, contiene todos los modelos que se necesitan en el laboratorio. También incluye cucharones, palas, embudos y gradillas para tubos. Además aquí encontrará crisoles y cápsulas fabricadas con níquel puro (99,5%).

- **Transportbehälter mit Deckel und Henkel**
- **Container with lid and handle**
- **Container inox à anse et couvercle**
- **Contenedor con tapa y asa**

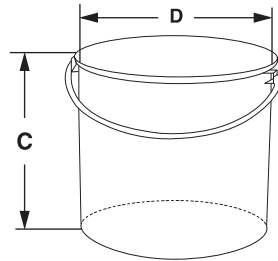

Material	C	D	Ltr	Artikel Nr.
18/10-STAHL	140	100	1	8300
18/10-STAHL	150	130	2	8301
18/10-STAHL	180	155	3	8302
18/10-STAHL	240	175	5	8304
18/10-STAHL	280	175	6	8305
18/10-STAHL	300	220	10	8307

■ **Sicherheitstransportbehälter für Laborflaschen**

8300SS: Laborflaschen 50–250 ml

8301SS: Laborflaschen 500–1000 ml

Mit Scharnier, Verschluss, Silikondichtung

■ **Safety transport container for laboratory flasks**

8300SS: Laboratory flasks 50–250 ml

8301SS: Laboratory flasks 500–1000 ml

With hinge, lock and silicon seal

■ **Conteneur de sécurité pour fioles de laboratoire**

8300SS: Fioles de laboratoire 50–250 ml

8301SS: Fioles de laboratoire 500–1000 ml

Avec charnière, fermeture, joint silicone

■ **Contenedor de seguridad para transporte de matraces de laboratorio**

8300SS: Matraces de laboratorio 50–250 ml

8301SS: Matraces de laboratorio 500–1000 ml

Con bisagras, cierre, junta de silicona

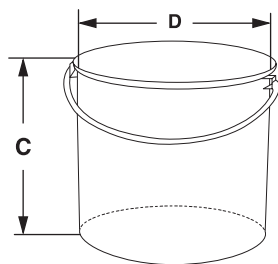

Material	C	D	Ltr	Artikel Nr.
18/10-STAHL	140	100/130	1	8300SS
18/10-STAHL	250	130/160	2	8301SS
SILIKON	130			18300SS
SILIKON	160			18301SS

■ **Transportbehälter (8340-48) und Deckel (8350-58)**

Deckel bitte separat bestellen.

■ **Container (8340-48) and lids (8350-58)**

Please order lids separately.

■ **Container inox à poignées (8340-48) et couvercles (8350-58)**

Commandez les couvercles séparément.

■ **Contenedor (8340-48) y tapas (8350-58)**

Las tapas se venden por separado

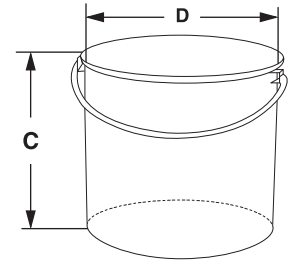

Material	C	D	Ltr	Artikel Nr.
Behälter / Container / Récipients / Contenedores				
18/10-STAHL	375	270	20	8340
18/10-STAHL	375	300	25	8341
18/10-STAHL	440	300	30	8342
18/10-STAHL	550	350	50	8344
18/10-STAHL	600	400	75	8346
18/10-STAHL	670	450	100	8347
18/10-STAHL	670	550	150	8348
Deckel / Lids / Couvercles / Tapas				
18/10-STAHL		270		8350
18/10-STAHL		300		8351
18/10-STAHL		300		8352
18/10-STAHL		350		8354
18/10-STAHL		400		8356
18/10-STAHL		450		8357
18/10-STAHL		550		8358

■ **Spannklammern montiert**

Für alle Transportbehälter, 3 Stück, (8300-07/8340-48)

■ **Locking clamps mounted**

For all container, 3 pieces, (8300-07/8340-48)

■ **Pinces de fermeture montée en usine**

Pour tous les containers, 3 pièces, (8300-07/8340-48)

■ **Pinzas de cierre, montadas en fábrica**

Para todas los contenedores, 3 piezas, (8300-07/8340-48)



Material	Artikel Nr.
18/10-STAHL	8349

■ **NO-DRIP Auslaufhahn 1/2" montiert**

PTFE Dichtung, max. 260°C

■ **NO-DRIP stopcock 1/2" mounted**

PTFE seal, max. 260°C

■ **NO-DRIP robinet de vidange 1/2", monté en usine**

PTFE joint, max. 260°C

■ **Grifo NO-DRIP 1/2", montado en fábrica**

Junta de PTFE, max. 260°C



Material	Artikel Nr.
18/10-STAHL	8359

■ **Feuerhemmender Abfallbehälter**

Mit Schwingdeckel, Griffe rechts und links, jeweils +25 mm, PVC-Beutel Nr. 11421 (Set à 25 Stück)

■ **Safety litter box**

With swinging lid, handles left and right, each side +25 mm, PVC-bag no. 11421 (Set with 25 pieces)

■ **Poubelle de sécurité**

Avec couvercle basculant, anses à droite et à gauche, 2x +25 mm, sac-PVC no. 11421 (à 25 pièces)

■ **Cubo de basura de seguridad**

Con tapa basculante, asas a la derecha e izquierda, 2x +25 mm, bolsa de PVC código 11421 (unidad de 25)

NEW!



Material	A	B	C	Artikel Nr.
18/10-STAHL	410	310	745	11422
PVC (25 Stück/pieces/pièces/unidades)				11421

■ **Kanister mit Schraubverschluss**

■ **Canister with screw**

■ **Jerrycan avec bouchon vissé**

■ **Lata con tapón roscado**



Material	Ltr	Artikel Nr.
18/10-STAHL	20	11425
18/10-STAHL	10	11426
Auslaufrohr/tube/tubo/tubo		11427

■ **Einmal Alu-Schalen, 1 Packung à 100 Stück**

■ **Disposable alu dishes, 1 package 100 pieces**

■ **Couppelles alu à usage unique, 1 paquet à 100 pièces**

■ **Cápsulas desechables de aluminio, 1 paquete de 100 piezas**



Material	C	D	ML	Artikel Nr.
ALU	13	64	28	11610
ALU	25	99	110	11611
ALU	24	96	125	11613
ALU	50	114	280	11615

■ **Wasserbad mit Deckel**

■ **Water bath with lid**

■ **Récipients avec couvercle**

■ **Baño de agua con tapa**

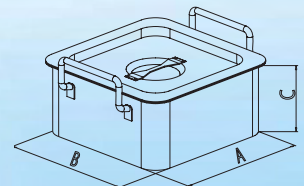

Material	A	B	C	Ltr	Artikel Nr.
18/10-STAHL	155	105	75	1,0	8461
18/10-STAHL	155	105	160	2,5	8463
18/10-STAHL	155	155	235	5,0	8466
18/10-STAHL	240	240	235	13,0	8468

■ **Isolierbehälter doppelwandig mit Deckel**

Stapelbar

■ **Isolate container with lid, double wall**

Stackable

■ **Container isolant avec couvercle, double paroi**

Empilable

■ **Contenedor aislante con tapa, doble pared**

Apilable

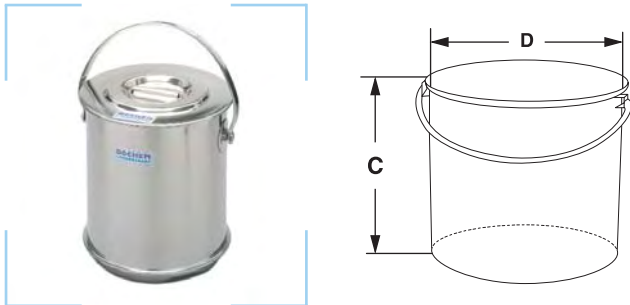

Material	C	D	Ltr	Artikel Nr.
18/10-STAHL	285	175/215	5	8081
18/10-STAHL	325	220/260	10	8082

■ **Eimer (8320-22) und Deckel (8332-34), graduert**

Deckel bitte separat bestellen.

■ **Buckets (8320-22) and lids (8332-34), graduated**

Please order lids separately.

■ **Seau (8320-22) et couvercle (8332-34), graduée**

Commandez les couvercles séparément.

■ **Cubos (8320-22) y Tapas (8332-34), graduados**

Las tapas se venden por separado



Material	C	D	Ltr	Typ	Artikel Nr.
Eimer / Buckets / Seaux / Cubos					
18/10-STAHL	190	260	6	2	8320
18/10-STAHL	210	285	8	2	8321
18/10-STAHL	235	280	10	2	8322
18/10-STAHL	270	300	12	2	8323
18/10-STAHL	305	310	15	2	8324
18/10-STAHL	235	280	10	1	8315
18/10-STAHL	270	300	12	1	8316
18/10-STAHL	305	310	15	1	8317
Deckel / Lids / Couvercles / Tapas					
18/10-STAHL		280			8332
18/10-STAHL		300			8333
18/10-STAHL		310			8334

■ **Transportkanne**

Mit Henkel, Deckel und Ausguss

■ **Transport jug**

With handle, lid and spout

■ **Bidon de transport**

Avec anse, couvercle et bec

■ **Jarra de transporte**

Con asa, tapa y pico



Material	C	D	Ltr	Artikel Nr.
18/10-STAHL	275	175	5	8380
18/10-STAHL	350	220	10	8381
18/10-STAHL	440	270	20	8384

■ **Messkannen graduert, mit Ausguss**

Deckel bitte separat bestellen.

■ **Measuring bucket graduated, with spout**

Please order lids separately.

■ **Seau gradué, avec bec**

Commandez les couvercles séparément.

■ **Cubo de medida con pico, graduado**

Las tapas se venden por separado

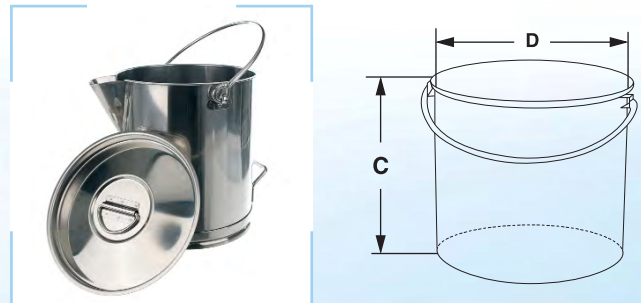

Material	C	D	Ltr	Artikel Nr.
Eimer / Buckets / Seaux / Cubos				
18/10-STAHL	250	240	10	8390
18/10-STAHL	300	270	15	8391
Deckel / Lids / Couvercles / Tapas				
18/10-STAHL		240		8392
18/10-STAHL		270		8393

- **Labortopf mit Deckel, Aluminium**
- **Laboratory pot with lid, aluminium**
- **Récipients avec couvercle, aluminium**
- **Cacerolas de laboratorio con tapa, aluminio**

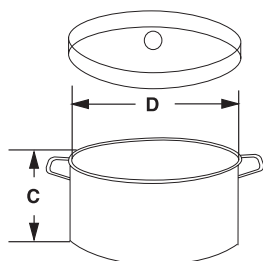

Material	C	D	Ltr	Artikel Nr.
ALU	100	160	1,5	8566
ALU	120	200	3,0	8567
ALU	140	260	5,2	8568

■ **Labortopf und Deckel**

Deckel bitte separat bestellen.

■ **Pots laboratory and lids**

Please order lids separately.

■ **Récipients et couvercles**

Commandez les couvercles séparément.

■ **Cacerolas de laboratorio y Tapas**

Las tapas se venden por separado.

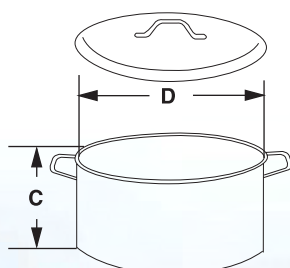

Material	C	D	Ltr	Artikel Nr.
Topf / Pots / Récipients / Cacerolas				
18/10-STAHL	128	160	2	8360
18/10-STAHL	144	180	3	8361
18/10-STAHL	160	200	4	8362
18/10-STAHL	176	220	5	8363
18/10-STAHL	192	240	9	8364
18/10-STAHL	208	260	12	8365
18/10-STAHL	222	300	15	8366
18/10-STAHL	280	300	20	8367
Deckel / Lids / Couvercles / Tapas				
18/10-STAHL		160		8370
18/10-STAHL		180		8371
18/10-STAHL		200		8372
18/10-STAHL		220		8373
18/10-STAHL		240		8374
18/10-STAHL		260		8375
18/10-STAHL		300		8376
18/10-STAHL		300		8377

■ **Becher**

Typ 1: mit Rand

Typ 2: mit Rand/Ausguss

Typ 3: mit Rand/Griff

Typ 4: mit Rand/Ausguss/Griff

■ **Beakers**

Type 1: with rim

Type 2: with rim/spout

Type 3: with rim/handle

Type 4: with rim/spout/handle

■ **Béchers**

Type 1: avec bord

Type 2: avec bord + bec

Type 3: avec bord + anse

Type 4: avec bord + bec + anse

■ **Vasos**

Modelo 1: con borde

Modelo 2: con borde/pico

Modelo 3: con borde /asa

Modelo 4: con borde/pico/asa

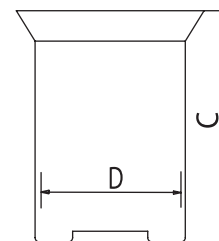

Typ 2



Typ 4

Material	C	D	ML	Typ	Artikel Nr.
18/10-STAHL	60	50	100	1	8500
18/10-STAHL	85	65	250	1	8501
18/10-STAHL	110	80	500	1	8502
18/10-STAHL	130	100	1000	1	8503
18/10-STAHL	180	120	2000	1	8504
18/10-STAHL	180	150	3000	1	8505
18/10-STAHL	210	180	5000	1	8506
18/10-STAHL	60	50	100	2	8510
18/10-STAHL	85	65	250	2	8511
18/10-STAHL	110	80	500	2	8512
18/10-STAHL	130	100	1000	2	8513
18/10-STAHL	180	120	2000	2	8514
18/10-STAHL	180	150	3000	2	8515
18/10-STAHL	210	180	5000	2	8516
18/10-STAHL	60	50	100	3	8520
18/10-STAHL	85	65	250	3	8521
18/10-STAHL	110	80	500	3	8522
18/10-STAHL	130	100	1000	3	8523
18/10-STAHL	180	120	2000	3	8524
18/10-STAHL	180	150	3000	3	8525
18/10-STAHL	210	180	5000	3	8526
18/10-STAHL	60	50	100	4	8530
18/10-STAHL	85	65	250	4	8531
18/10-STAHL	110	80	500	4	8532
18/10-STAHL	130	100	1000	4	8533
18/10-STAHL	180	120	2000	4	8534
18/10-STAHL	180	150	3000	4	8535
18/10-STAHL	210	180	5000	4	8536

- Haltegriff für Glasbecher
- Handle for glass beaker
- Poignée pour bécher en verre
- Asa para vasos de vidrio



Material	D	Artikel Nr.
18/10-STAHL	80/100	8993
18/10-STAHL	140/155	8995
18/10-STAHL	170/190	8996

- Deckelbüchse
- Dressing jar with lid
- Boîte à coton avec couvercle
- Bote para algodón con tapa

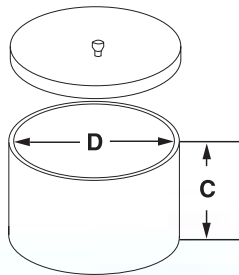

Material	C	D	ML	Artikel Nr.
18/10-STAHL	60	60	100	8581
18/10-STAHL	85	85	400	8584
18/10-STAHL	100	100	700	8585
18/10-STAHL	120	120	1200	8587
18/10-STAHL	150	150	2500	8588
18/10-STAHL	200	200	6000	8693

- Büchse mit Deckel
- Deckel mit Griff, stapelbar
- Dressing jar with lid
- Lid with handle, stockable
- Boîte à coton avec couvercle
- Couvercle avec poignée, empilable
- Bote para algodón con tapa
- Tapa con mango, botes apilables

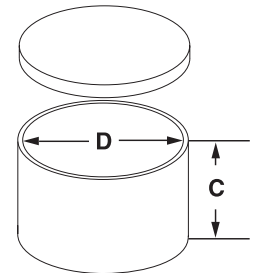

Material	C	D	Artikel Nr.
18/10-STAHL	80	102	8620
18/10-STAHL	130	102	8621
18/10-STAHL	130	124	8622
18/10-STAHL	165	124	8623
18/10-STAHL	180	180	8624

- Deckelbüchse, Aluminium
- Dressing jar with lid, aluminium
- Boîte à coton avec couvercle, aluminium
- Bote para algodón con tapa, aluminio



Typ 1



Typ 2

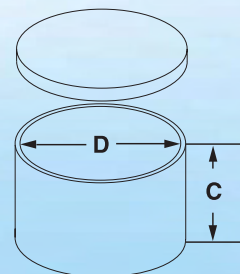

Material	C	D	Typ	Artikel Nr.
ALU	20	60	1	8760
ALU	20	80	1	8761
ALU	20	100	1	8762
ALU	50	50	2	8770
ALU	85	65	2	8771
ALU	110	80	2	8772

■ Messbecher graduert, zylindrische Form

Graduierung 200 ml

■ Measuring jug graduated, cylindrical shape

Graduation 200 ml

■ Bêcher gradué, forme cylindrique

Graduation 200 ml

■ Jarra de medida, forma cilíndrica

Graduada 200 ml

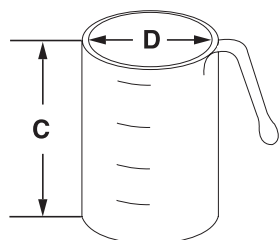

Material	C	D	ML	Artikel Nr.
18/10-STAHL	140	100	1000	8640
18/10-STAHL	170	130	2000	8642

■ Messbecher graduert, konische Form

Graduierung 100 ml

■ Measuring jug graduated, conical shape

Graduation 100 ml

■ Bêcher gradué, forme conique

Graduation 100 ml

■ Jarra de medida, forma cónica

Graduada 100 ml

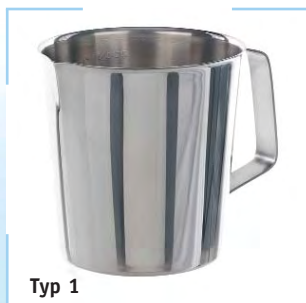

Typ 1

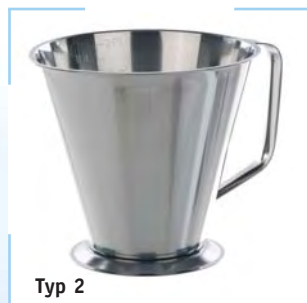

Typ 2

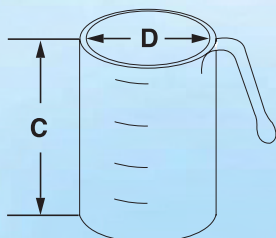

Material	C	D	ML	Typ	Artikel Nr.
18/10-STAHL	95	125	500	1	8650
18/10-STAHL	120	135	1000	1	8651
18/10-STAHL	145	175	2000	1	8652
18/10-STAHL	115	115	500	2	8660
18/10-STAHL	160	140	1000	2	8661
18/10-STAHL	160	150	1500	2	8662
18/10-STAHL	185	160	2000	2	8663

■ Instrumentenschale mit Deckel

■ Instruments tray with lid

■ Boîte rectangulaire avec couvercle

■ Bandeja para instrumental con tapa, con pomo

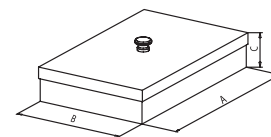

Material	A	B	C	Artikel Nr.
18/10-STAHL	160	100	30	8710
18/10-STAHL	180	120	50	8711
18/10-STAHL	200	100	50	8712
18/10-STAHL	220	150	50	8713
18/10-STAHL	280	180	60	8714
18/10-STAHL	300	150	100	8715
18/10-STAHL	300	200	50	8716
18/10-STAHL	500	200	80	8717

■ Instrumentenschale mit Deckel

■ Instruments tray with lid

■ Boîte rectangulaire avec couvercle

■ Bandeja para instrumental con tapa

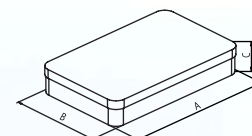

Material	A	B	C	Artikel Nr.
18/10-STAHL	210	150	40	8630
18/10-STAHL	240	180	40	8631
18/10-STAHL	270	210	40	8632
18/10-STAHL	300	240	40	8633
18/10-STAHL	360	300	40	8634

- Instrumentenschale mit Deckel
- Instruments tray with lid
- Boîte rectangulaire avec couvercle
- Bandeja para instrumental con tapa

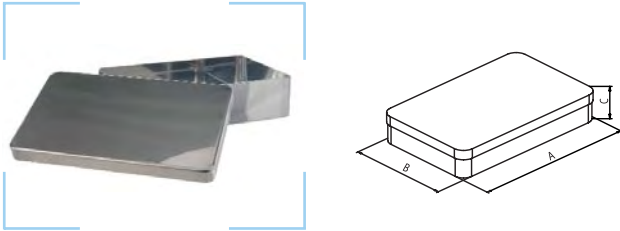

Material	A	B	C	Artikel Nr.
18/10-STAHL	180	90	30	8400
18/10-STAHL	215	100	50	8404
18/10-STAHL	250	150	60	8406
18/10-STAHL	300	150	70	8407

- Instrumentenschale mit Deckel
- Deckel mit Griff
- Instruments tray with lid
- Lid with handle
- Boîte rectangulaire avec couvercle
- Couvercle avec poignée
- Bandeja para instrumental
- Apilable

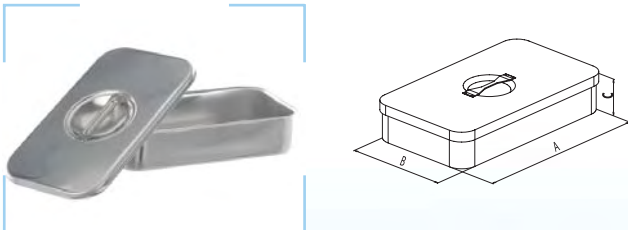

Material	A	B	C	Artikel Nr.
18/10-STAHL	230	133	45	8475
18/10-STAHL	315	215	60	8476

- Instrumentenablage
- Instruments tray
- Plateau rectangulaire
- Bandeja para instrumental



Material	A	B	C	Artikel Nr.
18/10-STAHL	200	175	15	8480
18/10-STAHL	300	200	15	8484
18/10-STAHL	300	300	20	8485
18/10-STAHL	440	340	20	8486

- Fotoschale
- Runde Ecken
- Tray laboratory
- Round corners
- Cuvettes
- Coins ronds
- Cubetas para laboratorio
- Esquinas redondeadas

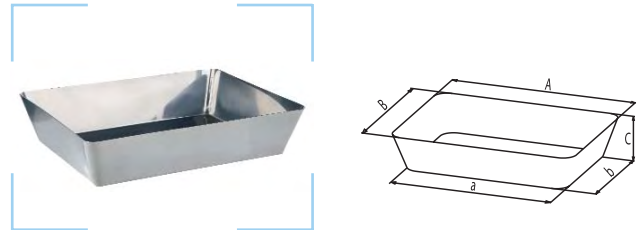

Material	a	A	b	B	C	Artikel Nr.
18/10-STAHL	190	225	140	175	50	8700
18/10-STAHL	250	290	180	220	60	8701
18/10-STAHL	260	290	190	225	50	8702
18/10-STAHL	320	355	260	305	60	8703
18/10-STAHL	350	400	240	280	70	8704
18/10-STAHL	400	450	270	320	80	8705
18/10-STAHL	500	560	330	385	100	8706

- Verdampfschale mit Rand
- Evaporating dish with rim
- Cristallisoirs avec rebord
- Cubetas con reborde

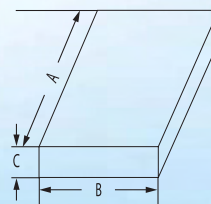

Material	A	B	C	Typ	Artikel Nr.
18/10-STAHL	220	155	40	1	8454
18/10-STAHL	240	160	50	1	8455
18/10-STAHL	310	200	45	1	8456
18/10-STAHL	340	210	60	1	8457
18/10-STAHL	375	270	45	1	8459
18/10-STAHL	290	190	55	2	8395
18/10-STAHL	335	245	60	2	8396
18/10-STAHL	385	280	65	2	8397
18/10-STAHL	445	280	95	2	8398
18/10-STAHL	500	335	100	2	8399

- Schalen mit 2 Griffen
- Trays with 2 handles
- Boîtes rectangulaires avec 2 anses
- Bandeja con 2 asas

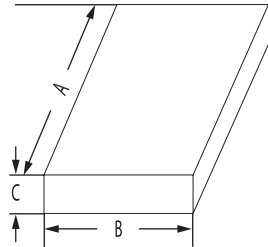

Material	A	B	C	Artikel Nr.
18/10-STAHL	250	180	70	8735
18/10-STAHL	350	250	70	8736

- Chemikalienschaufel
- Chemical scoop
- Pelle inox
- Palas para productos químicos

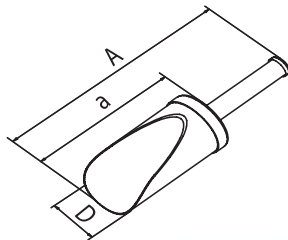

Material	A	a	D	Ltr	Artikel Nr.
18/10-STAHL	190	100	50	0,12	8800
18/10-STAHL	250	145	75	0,45	8801
18/10-STAHL	320	190	105	1,00	8802
18/10-STAHL	350	230	120	1,50	8803
18/10-STAHL	370	250	150	2,00	8804

- Apotheken-Schaufel Griff verlötet
- Pharmacy-Scoop Handle soldered
- Pelle de pharmacie Manche soudé
- Palas para uso farmacéutico Mango soldado

NEW!



Material	A	a	D	Artikel Nr.
18/10-STAHL	220	120	50	8830
18/10-STAHL	280	165	75	8831

- Pharma-Schaufeln, 18/10 Stahl
- Pharma scoops, stainless steel 18/10
- Pelles pharmaceutiques, acier inox 18/10
- Palas para uso farmacéutico, acero inox 18/10

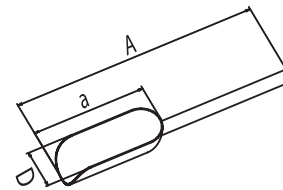

Material	A	a	D	Ltr	Artikel Nr.
18/10-STAHL	215	100	40	0,15	8809
18/10-STAHL	310	160	82	0,25	8810
18/10-STAHL	350	200	102	0,5	8811
18/10-STAHL	390	220	120	1,0	8812
18/10-STAHL	450	300	160	2,0	8813

- Chemikalienschaufel Aluminium
- Chemical scoop aluminium
- Pelle aluminium
- Palas para productos químicos, aluminio

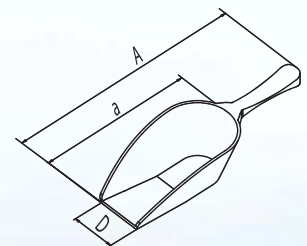

Material	A	a	D	ML	Artikel Nr.
ALU	65	40	12	5	8814
ALU	85	52	13	10	8815
ALU	135	80	24	50	8816
ALU	155	95	30	65	8817
ALU	185	115	32	90	8818
ALU	210	120	37	160	8819
ALU	250	145	45	240	8820
ALU	290	175	55	400	8821
ALU	310	185	57	480	8822
ALU	350	220	63	900	8823
ALU	400	270	83	1600	8824
ALU	430	300	95	2500	8825
ALU	250	120	35	90	8827
ALU	285	120	35	90	8828
ALU	365	120	35	90	8829

- Wägeschaukel
- Weighing scoop
- Pelle pour balance
- Navecillas de pesada

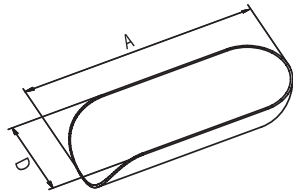

Material	A	D	Artikel Nr.
18/10-STAHL	70	32	12800
18/10-STAHL	90	32	12801
18/10-STAHL	105	32	12802
18/10-STAHL	120	32	12803
18/10-STAHL	120	30-65	12804
18/10-STAHL	160	30-75	12805
18/10-STAHL	200	55-100	12806
ALU	70	32	12810
ALU	90	32	12811
ALU	105	32	12812
ALU	120	32	12813

- Schöpfkelle, runder Griff
- Ladle scoop, round handle
- Louche inox, manche rond
- Cucharón, mango fino

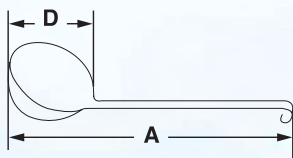

Material	A	D	ML	Artikel Nr.
18/10-STAHL	300	60	50	8790
18/10-STAHL	300	70	80	8791
18/10-STAHL	300	80	130	8792
18/10-STAHL	300	90	210	8793
18/10-STAHL	400	100	250	8794
18/10-STAHL	400	120	450	8795
18/10-STAHL	400	140	670	8796
18/10-STAHL	400	160	1000	8797
18/10-STAHL	500	200	2000	8799

- Schöpfkelle, flacher Griff
- Ladle scoop, flat handle
- Louche inox, manche plat
- Cucharón, mango plano

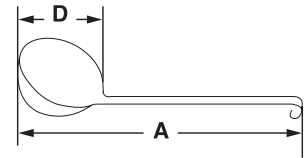

Material	A	D	ML	Artikel Nr.
18/10-STAHL	230	70	50	8740
18/10-STAHL	280	90	125	8741
18/10-STAHL	300	100	250	8742
18/10-STAHL	350	140	750	8743
18/10-STAHL	500	160	1000	8744
18/10-STAHL	500	180	1500	8745

- Pipettenbüchse, rund

Silikon im Boden u. Deckel
Bis 205°C sterilisierbar

- Pipette box, round

Silicone covered bottom and lid
Sterilizable up to 205°C

- Boîte à pipettes, forme ronde

Protection silicone sur fond et couvercle
Stérilisable jusqu'à 205°C

- Cajas para pipetas cilíndricas

Fondo y tapa recubierto de silicona
Esterilizable hasta 205°C

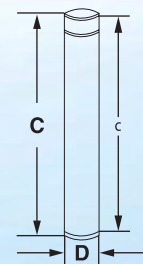

Material	C	c	D	Artikel Nr.
18/10-STAHL	390	382	50	8980
18/10-STAHL	425	417	50	8981
18/10-STAHL	380	372	65	8982
18/10-STAHL	450	442	65	8983
18/10-STAHL	380	372	80	8984
18/10-STAHL	500	492	80	8985

■ **Pipettenbüchse eckig**

Silikon im Boden und Deckel
Bis 205°C sterilisierbar

■ **Pipette box square**

Silicon covered bottom and lid
Sterilizable up to 205°C

■ **Boîte à pipettes inox, forme carré**

Protection silicone sur fond et couvercle
Stérilisable jusqu'à 205°C

■ **Cajas para pipetas base cuadrada**

Fondo y tapa recubiertos de silicona
Esterilizable hasta 205°C

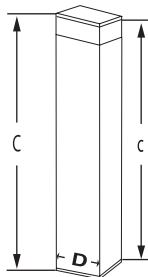

Material	C	c	D	Artikel Nr.
18/10-STAHL	210	202	70x70	8870
18/10-STAHL	290	282	70x70	8871
18/10-STAHL	340	332	70x70	8872
18/10-STAHL	435	427	70x70	8873
18/10-STAHL	490	482	70x70	8874

■ **Sterilisierbehälter für Petrischalen Ø 100 mm (8541)**

für 10 Schalen

■ **Sterilizing box for Petri-dishes Ø 100 mm (8541)**

for 10 dishes

■ **Boîte de stérilisation en inox pour boîtes de Pétri**

Ø 100 mm (8541)

pour 10 boîtes

■ **Caja para esterilizar placas Petri Ø 100mm (8541)**

10 placas

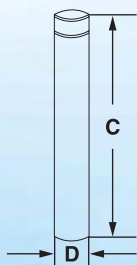

Material	C	D	Typ	Artikel Nr.
18/10-STAHL	250	120	10 x	8961

■ **Petrischalen**

■ **Petri dishes**

■ **Boîtes de Pétri**

■ **Placas Petri**

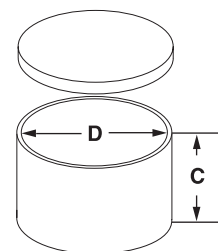

Material	C	D	Artikel Nr.
18/10-STAHL	15	100	8541
18/10-STAHL	20	60	8635
18/10-STAHL	20	75	8636
18/10-STAHL	20	90	8637
18/10-STAHL	20	120	8638

■ **Sandbadschale, flacher Boden**

■ **Bowl, flat bottom**

■ **Bol, fond plat**

■ **Bol, fondo plano**

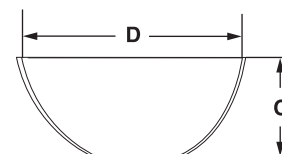

Material	C	D	ML	Artikel Nr.
18/10-STAHL	40	80	100	8670
18/10-STAHL	50	100	250	8671
18/10-STAHL	60	120	500	8672
18/10-STAHL	80	160	1000	8673
18/10-STAHL	100	200	2000	8674
18/10-STAHL	120	250	5000	8677

■ **Sandbadschale mit 2 Griffen**

■ **Bowl with 2 handles**

■ **Bol avec 2 poignées**

■ **Bol con 2 asas**

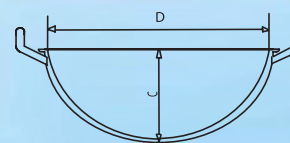

Material	C	D	ML	Artikel Nr.
18/10-STAHL	120	220	2700	8445
18/10-STAHL	140	260	4000	8446
18/10-STAHL	180	320	9500	8447
18/10-STAHL	190	360	12000	8448

- Abdampfschale, flache Form
- Evaporating dish, flat shape
- Cristallisoir, forme basse
- Cápsula de evaporación forma plana

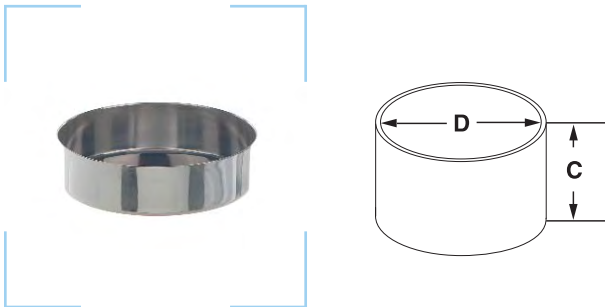

Material	C	D	ML	Artikel Nr.
18/10-STAHL	20	60	50	8570
18/10-STAHL	20	70	75	8571
18/10-STAHL	20	80	100	8572

- Abdampfschale, hohe Form
- Evaporating dish, high shape
- Cristallisoir, forme haute
- Cápsula de evaporación forma alta



Material	C	D	ML	Artikel Nr.
18/10-STAHL	35	70	125	8560
18/10-STAHL	45	85	250	8561
18/10-STAHL	55	110	500	8562
18/10-STAHL	70	140	1000	8563
18/10-STAHL	105	160	2000	8564
18/10-STAHL	160	200	5000	8565

- Laborschale
- Laboratory bowl
- Cuvette de laboratoire
- Bol de laboratorio



Material	C	D	Ltr	Artikel Nr.
18/10-STAHL	70	185	1	8590
18/10-STAHL	70	250	2	8591
18/10-STAHL	95	265	3	8592
18/10-STAHL	125	280	4,5	8593
18/10-STAHL	120	335	6	8594
18/10-STAHL	145	360	8	8595
18/10-STAHL	135	415	11	8596
18/10-STAHL	160	430	14	8597

- Laborschale, hohe Form
- Laboratory bowl, high shape
- Cuvette de laboratoire, forme haute
- Bol de laboratorio, forma alta



Material	C	D	Ltr	Artikel Nr.
18/10-STAHL	73	150	0,75	8600
18/10-STAHL	90	175	1	8601
18/10-STAHL	92	197	1,5	8602
18/10-STAHL	115	217	2	8603
18/10-STAHL	120	245	3	8605
18/10-STAHL	123	270	4	8606
18/10-STAHL	135	300	5	8607
18/10-STAHL	135	320	6	8608
18/10-STAHL	160	350	8	8609
18/10-STAHL	175	350	9	8610
18/10-STAHL	180	395	11	8611

- Schale, runder Boden
- Bowl, round bottom
- Bol, fond rond
- Bol, fondo redondo

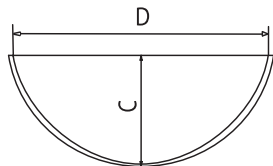

Material	C	D	ML	Artikel Nr.
18/10-STAHL	30	60	50	8780
18/10-STAHL	35	70	80	8781
18/10-STAHL	40	80	130	8782
18/10-STAHL	45	90	210	8783
18/10-STAHL	50	100	250	8784
18/10-STAHL	60	120	450	8785
18/10-STAHL	70	140	670	8786
18/10-STAHL	80	160	1000	8787
18/10-STAHL	100	200	2006	8789

■ Mörser + Pistill

Pistill Nr. 8936, separat bestellen

■ Mortar + pestle

Pestle no. 8936, order separatly

■ Mortiers + pilon

Pilon no. 8936, à commander séparément

■ Mortero + mano

Mano código 8936, pedir por separado

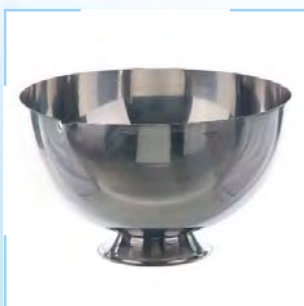

Material	A	D	ML	Artikel Nr.
18/10-STAHL		100	250	8930
18/10-STAHL		120	500	8931
18/10-STAHL		140	750	8932
18/10-STAHL		160	1000	8933
18/10-STAHL		180	1500	8934
18/10-STAHL		200	2000	8935
18/10-STAHL	140	28/24	-	8936

■ Verdampfschalen Nickel 99.5 %

Runder Boden, mit Ausguss

■ Evaporating dish nickel 99.5 %

Round bottom, with spout

■ Cristallisoirs nickel 99.5 %

Fond rond, avec bec

■ Cápsula de evaporación de níquel

Fondo redondo con pico

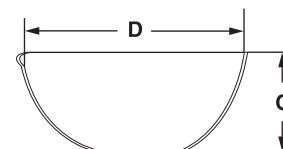

Material	C	D	ML	Artikel Nr.
NICKEL 99.5%	25	50	30	8020
NICKEL 99.5%	30	60	50	8021
NICKEL 99.5%	35	70	80	8022
NICKEL 99.5%	40	80	100	8023
NICKEL 99.5%	50	100	200	8024

■ Verdampfschalen Nickel 99.5 %

Flacher Boden

■ Evaporating dishes nickel 99.5 %

Flat bottom

■ Cristallisoirs nickel 99.5 %

Fond plat

■ Cápsula de evaporación, níquel

Fondo plano

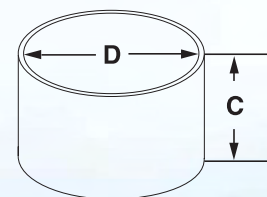

Material	C	D	ML	Artikel Nr.
NICKEL 99.5%	19	55	45	8040
NICKEL 99.5%	16	60	45	8041
NICKEL 99.5%	19	70	73	8042
NICKEL 99.5%	16	90	100	8045

■ **Verdampfschalen mit Deckel, Nickel 99.5 %**

Flacher Boden

■ **Evaporating dish with lid, nickel 99.5 %**

Flat bottom

■ **Cristallisoirs avec couvercle, nickel 99.5 %**

Fond plat

■ **Cápsula de evaporación con tapa de níquel**

Fondo plano

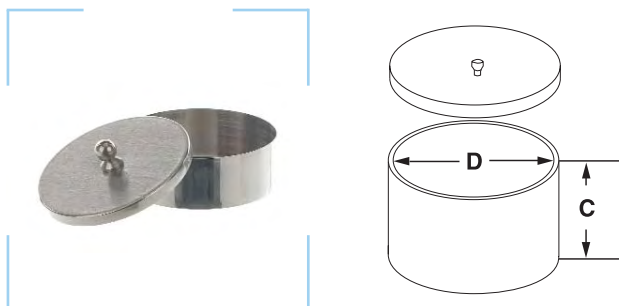

Material	C	D	ML	Artikel Nr.
NICKEL 99.5%	19	55	45	8060
NICKEL 99.5%	16	60	45	8061
NICKEL 99.5%	19	70	73	8062
NICKEL 99.5%	16	90	100	8065

■ **Tiegel und Deckel, Nickel 99.5 % + 18/10 Stahl**

Deckel bitte separat bestellen.

■ **Crucibles and lids, nickel 99.5 % + stainless steel 18/10**

Please order lids separately.

■ **Creusets + couvercles, nickel 99.5 % + acier inox 18/10**

Commandez les couvercles séparément.

■ **Crisoles y Tapas, níquel o acero inox 18/10**

Las tapas se venden por separado.



Typ 1: 0,5 mm

Typ 2: 1,0 mm

Typ 3: 1,5 mm

Typ 4: 2,0 mm

Material	C	D	ML	Typ	Artikel Nr.
Tiegel / Crucibles / Creusets / Crisoles					
NICKEL 99.5%	20	20	5	1	8100
NICKEL 99.5%	25	25	10	1	8101
NICKEL 99.5%	30	30	15	1	8102
NICKEL 99.5%	35	35	25	1	8103
NICKEL 99.5%	40	40	30	1	8104
NICKEL 99.5%	45	45	50	1	8105
NICKEL 99.5%	50	50	70	1	8106
NICKEL 99.5%	60	60	130	1	8107
NICKEL 99.5%	80	80	270	1	8109
NICKEL 99.5%	30	30	15	2	8122
NICKEL 99.5%	35	35	25	2	8123
NICKEL 99.5%	40	40	30	2	8124
NICKEL 99.5%	45	45	50	2	8125
NICKEL 99.5%	50	50	70	2	8126
NICKEL 99.5%	60	60	130	2	8127
NICKEL 99.5%	80	80	270	2	8129
NICKEL 99.5 %	45	45	50	3	8145
NICKEL 99.5%	40	40	30	4	8164
NICKEL 99.5%	50	50	70	4	8166
NICKEL 99.5%	60	60	130	4	8167
Deckel / Lids / Couvercles / Tapas					
NICKEL 99.5%		20			8180
NICKEL 99.5%		25			8181
NICKEL 99.5%		30			8182
NICKEL 99.5%		35			8183
NICKEL 99.5%		40			8184
NICKEL 99.5%		45			8185
NICKEL 99.5%		50			8186
NICKEL 99.5%		60			8187
NICKEL 99.5%		80			8189
Tiegel / Crucibles / Creusets / Crisoles					
18/10-STAHL	35	35	25	2	8881
18/10-STAHL	35	40	30	2	8882
18/10-STAHL	45	50	70	2	8883
Deckel / Lids / Couvercles / Tapas					
18/10-STAHL		35			8891
18/10-STAHL		40			8892
18/10-STAHL		50			8893

- Trichter
- Funnel
- Entonnoir
- Embudos



Material	C	c	D	d	Typ	Artikel Nr.
18/10-STAHL	115	50	80	12	1	8840
18/10-STAHL	125	65	100	12	2	8841
18/10-STAHL	145	80	120	13	2	8842
18/10-STAHL	190	90	150	17	2	8843
18/10-STAHL	220	90	200	18	2	8844
18/10-STAHL	260	90	250	18	2	8845
18/10-STAHL	320	115	300	22	3	8846
18/10-STAHL	430	135	400	50	3	8847

- Spezialtrichter
Gerades Rohr, für Pulver
- Special funnels
Tube straight, for powder
- Entonnoir spécial
Tube droit, pour poudre
- Embudos especiales
Tubo recto, para polvo

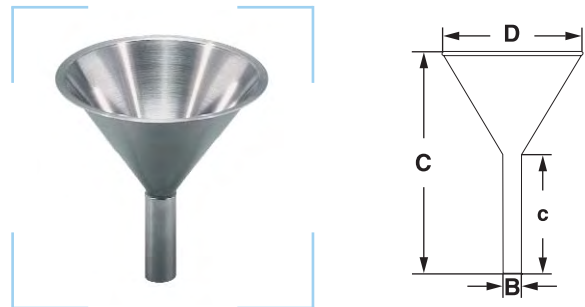

Material	C	c	D	d	Artikel Nr.
18/10-STAHL	140	60	120	20	8720
18/10-STAHL	150	60	155	30	8721
18/10-STAHL	180	60	200	30	8722
18/10-STAHL	220	60	240	30	8723

- Metallsieb für Fasstrichter
- Metal filter for funnel
- Tamis métallique adapté aux entonnoirs pour fûts
- Filtro metálico para embudos para barriles



Material	d	Artikel Nr.
KUPFER/KUNSTSTOFF	50	8851
18/10-STAHL	50	8852
KUPFER/KUNSTSTOFF	105	8853
18/10-STAHL	105	8854

■ Reagenzglasgestell mit Farbkennung

Kennzeichnung durch Farbköpfe (weiß, orange, gelb, blau, grün, rot)
1 Satz Farbköpfe inklusive
Autoklavierbar

■ Test tube rack with colour identification

Identification by coloured knobs (white, orange, yellow, blue, green, red)
1 set of coloured knobs included
Autoclavable

■ Porte-tubes à essai avec identification de couleur

Identification par boutons colorés (blanc, orange, jaune, bleue, vert, rouge)
1 set de boutons inclus
Autoclavable

■ Gradillas para tubos de ensayos con identificación de color

Identificación por botones de color (blanco, naranja, amarillo, azul, verde, rojo)
1 kit de botones incluido
Autoclavable

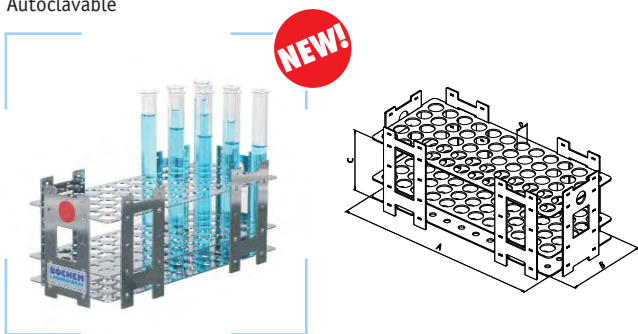

Material	A	B	C	D	Me/Qty	Me/Qty	Artikel Nr.
18/10-STAHL	248	104	60	13	5x12	60	8250
18/10-STAHL	248	104	85	16	5x12	60	8251
18/10-STAHL	248	104	85	20	4x10	40	8252
18/10-STAHL	248	104	85	25	3x7	21	8253
18/10-STAHL	248	104	100	30	3x7	21	8254

■ Reagenzglasgestell

■ Test tube stand

■ Porte-tubes à essai

■ Gradillas para tubos de ensayo

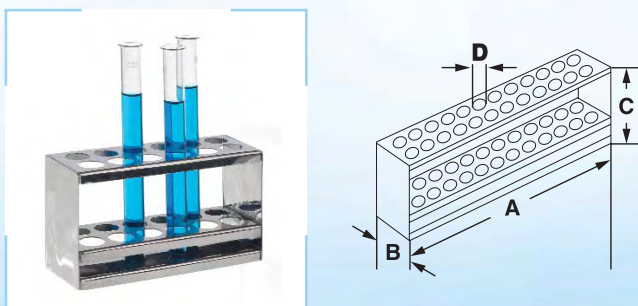

Material	A	B	C	D	Typ	Artikel Nr.
18/10-STAHL	145	52	90	17	2x6	8210
18/10-STAHL	278	52	90	17	2x12	8212
18/10-STAHL	287	97	90	17	4x12	8214
18/10-STAHL	164	60	90	20	2x6	8220
18/10-STAHL	310	60	90	20	2x12	8222

■ Reagenzglasgestell, rund

■ Test tube stand, round

■ Porte tubes à essai, forme ronde

■ Gradillas redondas para tubos de ensayo

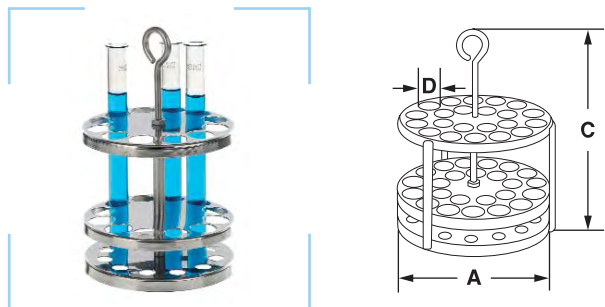

Material	A	C	D	Typ	Artikel Nr.
18/10-STAHL	98	165	20	9 x	8230
18/10-STAHL	116	165	20	12x	8231
18/10-STAHL	194	165	20	45x	8233

■ Reagenzglasgestell Z-Form

■ Test tube stand Z-shape

■ Porte-tubes à essai, forme Z

■ Gradillas para tubos de ensayo, forma Z



Material	A	B	C	D	Typ	Artikel Nr.
18/10-STAHL	50	165	85	13	10x5	8290
18/10-STAHL	50	220	110	17	10x5	8291
18/10-STAHL	50	85	85	13	5x5	8292
18/10-STAHL	50	110	110	17	5x5	8293